



**MAASAI MARA UNIVERSITY**  
**REGULAR UNIVERSITY EXAMINATIONS**  
**2021/2022 ACADEMIC YEAR**  
**FIRST YEAR FIRST SEMESTER**

**SCHOOL OF NATURAL RESOURCES, TOURISM  
AND HOSPITALITY**  
**BACHELOR OF URBAN AND REGIONAL PLANNING**

**COURSE CODE: URP 1105-1**  
**COURSE TITLE: INTRODUCTION TO TECHNICAL DRAWING**

**DATE: 1<sup>ST</sup> APRIL 2022**

**TIME: 1100-1300HR**

---

**INSTRUCTIONS TO CANDIDATES**

Answer **ALL** questions in **Section A** and any other **THREE** questions in **Section B**

**Instructions: Answer ALL questions in this Section.**

**SECTION A**

**(50MARKS)**

1. With the aid of a sketch, list the fundamentals of creating Depth, form and Space in Perspective drawing projections. (5Marks)
2. a. By the Aid of sketches, explain how one generates orthographic projections using vertical and horizontal planes (on a glass plane). (5Marks)  
  
b. Using sketches, differentiate between Oblique and axonometric projections. (5Marks)
3. By the aid of Sketches, explain five (5) elements of design, and their application to Urban and regional planning. (5Marks)
4. Blue prints are detailed drawings presented by an architect or engineer that outlines their design. List down five (5) elements a physical planner looks out for, when approving development drawings. (5Marks)
5. Discuss tools and equipment used in technical drawing and clearly outline their function (5Marks)

**SECTION B : Answer any THREE (3) questions in this section (50MARKS)**

6. By the aid of sketches, discuss one-point, two-point and three-point perspective drawing. (10Marks)
7. Using examples, discuss the application of technical drawing to Urban and Regional Planning (10Marks)

8. With the help of sketches, where applicable, explain 5 elements of design and 5 principles of design (10Marks)
9. Study the object below carefully and draw an orthographic projection showing the top view, front view, rear view and two side views (10Marks)

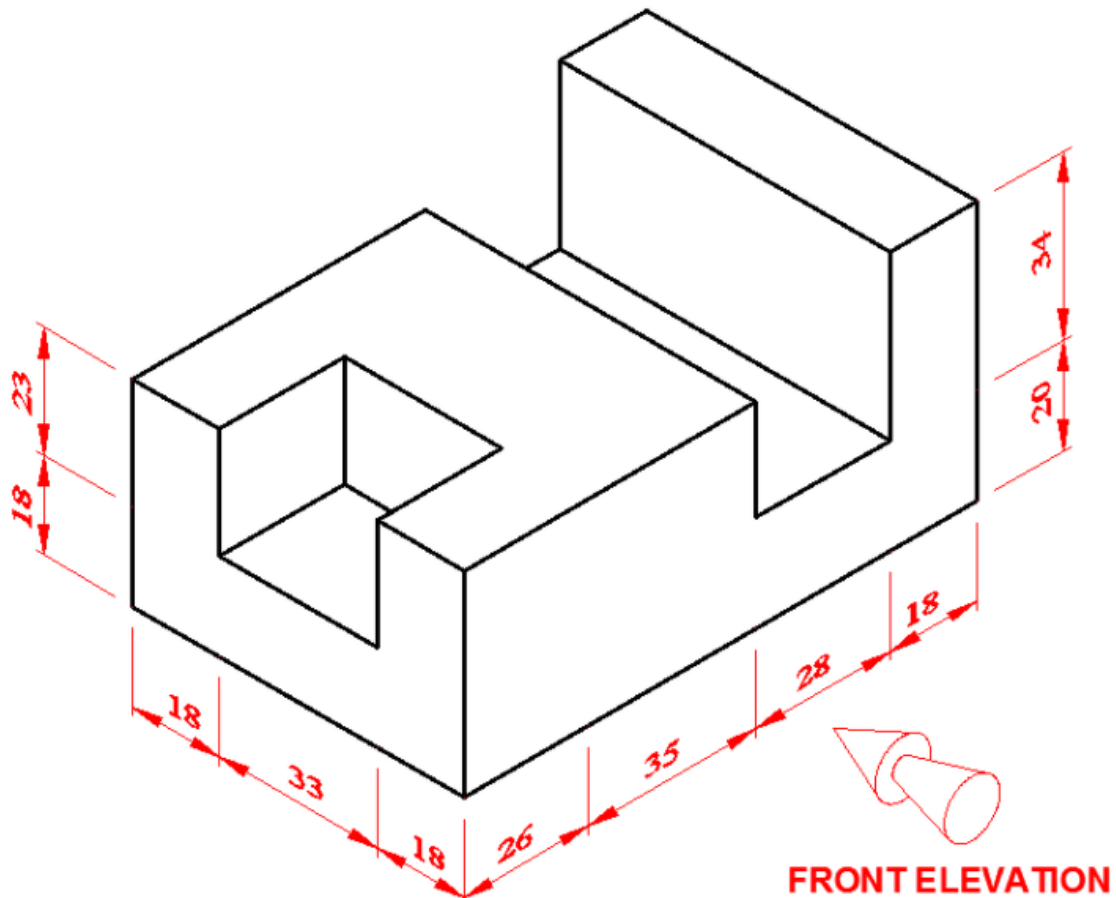

\*Viewing direction on side of the arrow.

/////END/////