



MAASAI MARA UNIVERSITY
REGULAR UNIVERSITY EXAMINATIONS
2022/2023 ACADEMIC YEAR
FIRST YEAR FIRST SEMESTER
SCHOOL OF PURE, APPLIED AND HEALTH
SCIENCES
BACHELOR OF SCIENCE
(COMPUTER SCIENCE)

COURSE CODE: COM 1104-1
COURSE TITLE: Computer Network
Essentials

7th April, 2022

8:30 – 10:30

INSTRUCTIONS TO CANDIDATES

(i) Answer Question **ONE** and any other **TWO** questions

This paper consists of 5 printed pages. Please turn over.

SECTION A (20 Marks): Answer all questions from this section

QUESTION 1

- (a) Identify three physical characteristics of fibre optic cables that makes them more suitable for high speed digital data transmission than copper cables (3 Marks)
- (b) The ISO Reference Model defines seven protocol layers, each of which is responsible for a specific range of functions. By considering this model, explain the main functions performed by a protocol operating at the following layers (2 Marks)
- (i) The Physical layer
 - (ii) The Transport layer
- (c) Identify and briefly describe three quality of service parameters that are often measured to characterise the behaviour of a network or network connection (3 Marks)
- (d) Explain how a network connection is established between a user and a server over the internet using the TCP protocol (3 Marks)
- (e) For each of the following application, determine whether you would use TCP or UDP (1 Mark)
- (i) File transfer
 - (ii) An audio conference
- (f) State and explain the two common physical WAN topologies (2 Marks)
- (g) Give the difference between Broadcast, and Multicast (1 Mark)
- (h) State two Network Penetration Testing Tools (1 Mark)
- (i) Give four tools that you can use to find errors in a network (2 Marks)
- (j) What is the importance of Network Address Translation (NAT) (1 Mark)
- (k) Why is it that when the load exceeds the network capacity, delay tends to infinity? (1 Mark)

SECTION B (30 Marks): Answer any two questions from this section.

QUESTION 2

- (a) Figure 1 shows part of a network in which two personal computers A and B, are each connected to a switch (LAN switch 1 and 2) which are themselves interconnected by a router. Consider the transmission of data from personal computer A to B and produce a protocol layer diagram that clearly shows how data passes through all of the layers of the ISO Reference model that are used within the PCs, switches and router. (5 marks)

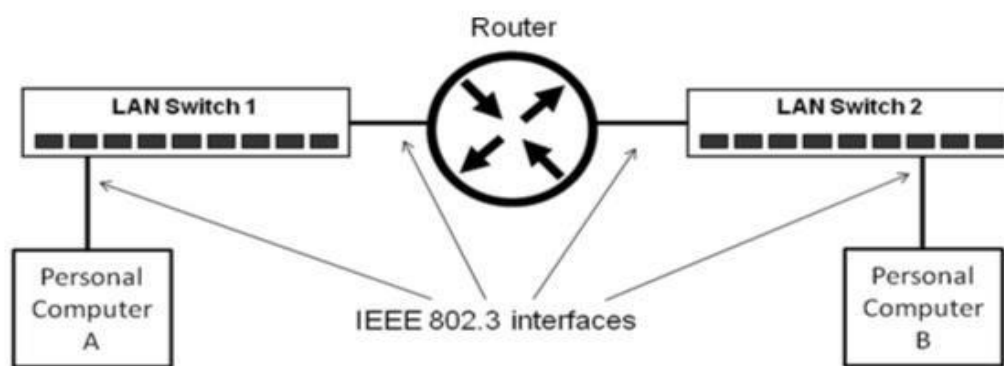
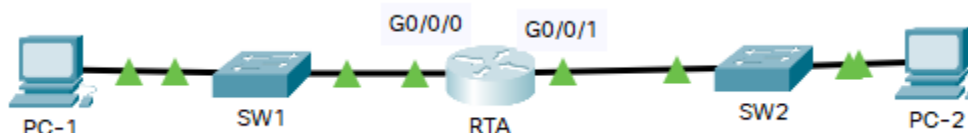

Figure 1

- (b) The following diagram shows two switches (SW1 and SW2), a router RTA and two Computers (PC-1 and PC-2).



Write the commands to perform the following operations on each of the switches (4 Marks)

- (i) Clear all configurations on the switches
 - (ii) Name the switches and the router
 - (iii) Assign an IP address to both router interfaces
 - (iv) Configure interface G0/1 on SW1 for trunking
- (c) State and explain three ways of building routes between nodes in large networks (3 Marks)
- (d) Discuss three reasons for implementing network segmentation (3 Marks)

QUESTION 3

- (a) Explain three security measures that can be used to protect users on wireless Networks (3 Marks)
- (b) In designing a LAN for an organization discuss the five most important things you'll put into consideration (5 Marks)
- (c) State and explain the switching techniques available for digital traffic (6 Marks)
- (d) What are the two basic functions of ARP (1 Mark)

QUESTION 4

- (a) Explain the purpose of the following with examples (2 Marks)
 - (i) Loopback addresses
 - (ii) Link-Local addresses
- (b) Find the class of the following addresses (2 Marks)
 - (i) 158.223.1.108
 - (ii) 227.13.14.88
- (c) Discuss any three limitations of copper cabling (3 Marks)
- (d) Imagine you have been appointed to design the network to be deployed in three new buildings on a new university campus. Building A contains a dedicated computer room containing 10 very high performance dedicated servers. The servers provide services to students and staff who may need to gain access from the Internet as well as from within the university's own network. Building B contains the offices of 12 lecturers and 8 administrators who only use medium power desktop computers located on fixed desks. Building C contains two lecture rooms and a lounge/coffee shop. The lecture rooms have a desktop computer at the front for use by the lecturers, but some lecturers prefer to use their own laptop or tablet computer. All the students use laptop or tablet computers to take notes and keep in touch with their friends. An underground duct exists between building A and building B which are only 30 metres apart. Building C is 30 metres from building A but no ducts exist and installing one is not possible.

- (i) What type of network should be deployed in the building that houses the dedicated computer room and what equipment should be installed? (2 Marks)
- (ii) What type of network should be deployed in the second office building and what equipment should be installed? (2 Marks)
- (iii) What type of network should be deployed in the teaching building and what equipment should be installed? (2 Marks)
- (iv) What type of network connections should be used to link the buildings together and where and how should the university's Internet connection be made? (2 Marks)