



MAASAI MARA UNIVERSITY

REGULAR UNIVERSITY EXAMINATIONS SECOND SEMESTER EXAMINATIONS 2018/2019 ACADEMIC YEAR SECOND THIRD YEAR EXAMINATIONS FOR BACHELOR OF SCIENCE IN COMPUTER SCIENCE

COURSE CODE: COM 2206

COURSE TITLE: AUTOMATA THEORY

DATE: 26TH APRIL 2019

TIME: 11:00 A.M – 1.00P.M.

Instructions

1. This paper contains FIVE questions. Answer question ONE (Compulsory) and any other TWO Questions
2. All optional questions carry equal marks
3. Write all your answers in the answer booklet
4. Time allowed; Two hours.

Question 1 [20 marks]

- a) Define the following (4 marks)
 - i. Automata Theory
 - ii. Alphabet
- b) If $\Sigma = \{0,1\}$, then Φ^* will result to? (1 mark)
- c) List and describe the parts of 5-tuple finite automata? (5 marks)
- d) Given: $\Sigma = \{a, b\}$ $L = \{x \in \Sigma^* | x \text{ is a string combination}\}$. What is Σ^4 ? (3 marks)
- e) Given Language $L = \{x \in (\Sigma^r)^* | \text{length of } x \text{ is at most } 2\}$ and $\Sigma = \{0,1\}$ give string combination (3 marks)
- f) Convert the following NFA into DFA (4 marks)

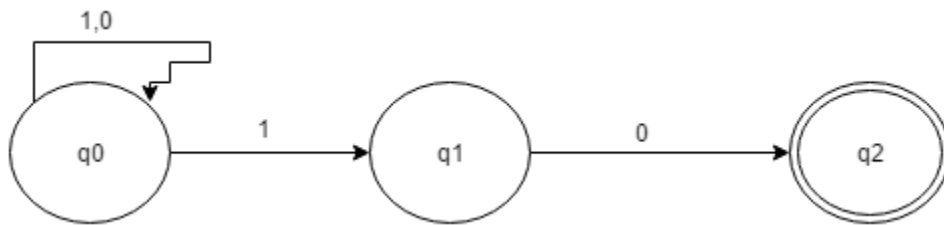

Question 2 [15 marks]

- a) What string does the following DFA accept? (hint string that ends with) (4 Marks)

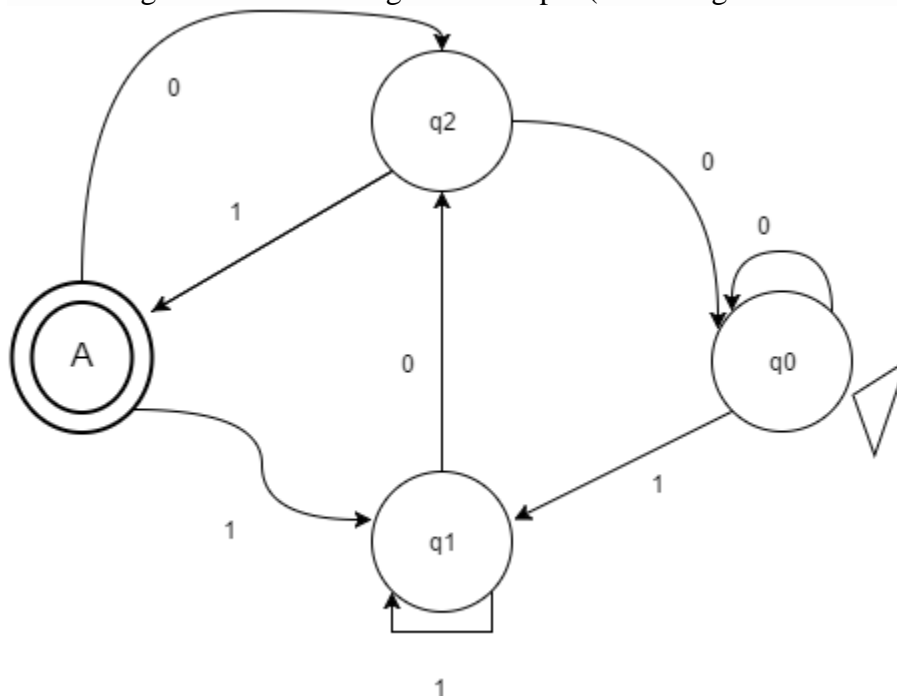

b) Design a DFA that accepts the following strings {abbbaa}, {abbbbaabb}, {abbaabbaa}. (4 marks)

c) Generate a Regular expression for which the given NFA corresponds to. (5 marks)

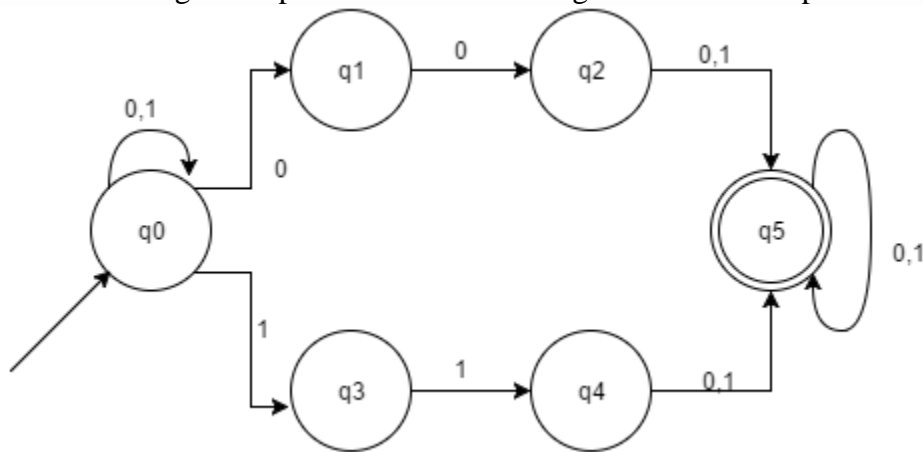

d) Give the appropriate precedence order of operations over a Regular Language. (2 marks)

Question 3[15 marks]

a) Describe the 7-tuple definition of Turing machine (7 marks)

b) Draw the transition a Turing machine which accepts the language with the regular expression {a,b}*{aba}. (5 marks)

c) Design a Turing machine to add two given integers (3 marks)

Question 4[15 marks]

a) What is an Ambiguous CFG? (2 mark)

b) State and explain any two ways to simplify a CFG to an NPDA (2 marks)

c) Consider The following Context-Free Grammar (CFG) G:

$$S \rightarrow XY$$

$$X \rightarrow aXb \mid \epsilon$$

$$Y \rightarrow bYc \mid \epsilon$$

Where S, X, Y are nonterminal symbol, S is the start symbol, and a, b, c are terminal symbols. Derive the CFG for the word: aaabbbbbbcc $\in L(G)$. (5 marks)

- d) Is the following CFG ambiguous? If yes, show this. If no, explain why. A and B are nonterminal,

$$A \rightarrow aBbA \mid aBbAcA \mid d$$

$$B \rightarrow e$$

A is the start symbol, a, b, c, d, and e are terminals. (6 marks)

Question 5[15 marks]

- a) What is a palindrome? Can the language pal of palindromes over the alphabet $\{0,1\}$ be accepted by a DPDA? (2 marks)

- b) Consider the following Context-Free Grammar (CFG):

$$S \rightarrow SpA \mid A$$

$$A \rightarrow BmA \mid B$$

$$B \rightarrow a \mid b \mid c \mid lSr$$

S, A, and B are nonterminals, a, b, c, l, m, p and r are terminals. S is the start symbol. Draw the derivation tree according to this grammar for the word: amlapbpcrma. (6 marks)

- c) Given the following Nondeterministic Finite Automaton, (NFA) over the alphabet $\Sigma = \{a, b, c\}$ construct a Deterministic Finite Automaton (DFA) D(N) equivalent to N. (7 marks) by applying the subset construction.

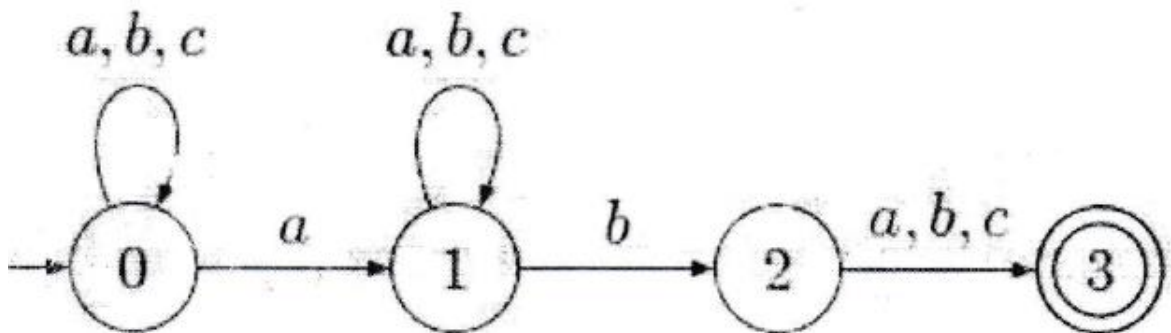

//END